

Abmessungen

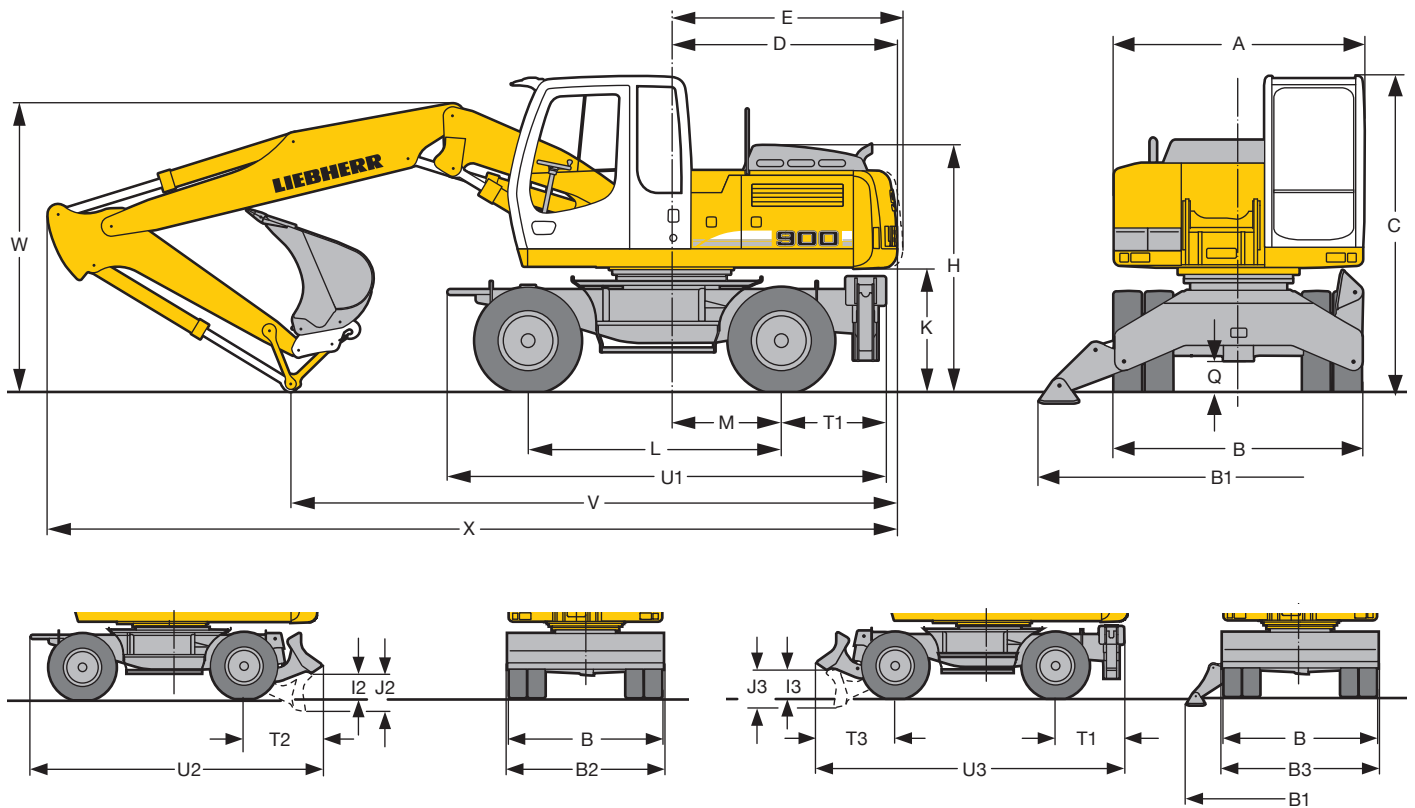

	mm
A	2.550
B	2.550
B ¹⁾	2.750
B1	3.690
B2	2.550
B2 ¹⁾	2.750
B3	2.550
C	3.160
D	2.260
E	2.330
H	2.465
I2	425
I3	380
J2	605
J3	585
K	1.235
L	2.540
M	1.100
Q	360
T1	1.050
T2	1.225
T3	1.155
U1	4.390
U2	4.575
U3	4.740

¹⁾ = EW-Unterwagen
E = Schwenkradius

Bereifung 10.00-20

	Löffel- stiel	Ausleger hydr. verstellbar 3,60 m				Monoblockausleger 5,00 m			
		Schild	2-Pkt.	Schild	4-Pkt. + 2-Pkt.	Schild	2-Pkt.	Schild	4-Pkt. + 2-Pkt.
	m	mm	mm	mm	mm	mm	mm	mm	mm
V	2,25	6.250	6.200	6.200	6.200	5.850	5.800	5.800	5.800
	2,45	5.950	5.900	5.900	5.900	5.450	5.400	5.400	5.400
	2,65	5.850	5.800	5.800	5.800	5.350	5.250	5.650	5.550*
W	2,25	3.050	3.050	3.050	3.050	3.150	3.150	3.150	3.150
	2,45	3.050	3.050	3.050	3.050	3.050	3.050	3.050	3.050
	2,65	3.100	3.100	3.100	3.100	3.100	3.100	3.100	3.100*
X	2,25	8.700	8.650	8.650	8.650	8.500	8.400	8.400	8.400
	2,45	8.700	8.650	8.650	8.650	8.450	8.400	8.400	8.400
	2,65	8.700	8.650	8.650	8.650	8.500	8.400	8.800	8.700*

	Löffel- stiel	Ausleger hoch- und seitenverstellbar 3,60 m				Monoblockausleger seitlich verstellbar 4,90 m			
		Schild	2-Pkt.	Schild	4-Pkt. + 2-Pkt.	Schild	2-Pkt.	Schild	4-Pkt. + 2-Pkt.
	m	mm	mm	mm	mm	mm	mm	mm	
V	2,25	6.250	6.150	6.100	6.150	6.250	6.150	6.150	6.150
	2,45	6.000	5.900	5.900	5.900	5.700	5.650	5.650	5.650
	2,65	5.900	5.800	5.800	5.800	5.300	5.250	5.650	5.500
W	2,25	3.050	3.050	3.050	3.050	3.150	3.150	3.150	3.150
	2,45	3.050	3.050	3.050	3.050	3.050	3.050	3.050	3.050
	2,65	3.150	3.150	3.150	3.150	3.000	3.000	3.000	3.000
X	2,25	8.700	8.650	8.650	8.650	8.350	8.300	8.300	8.300
	2,45	8.700	8.650	8.650	8.650	8.400	8.300	8.300	8.300
	2,65	8.700	8.650	8.650	8.650	8.400	8.300	8.750	8.600*

Ausrüstung dargestellt über Lenkachse

* Ausrüstung über Starrachse, da günstigere Transportstellung